

Research Notes on the
Lockheed 212 Electra
Compiled by John Griffin
Part 1/1

Version 1.0 – 4 May 2026

Scan of the original binder housed in the John Griffin Library,
1 Canadian Air Division

All pages were reproduced in the original order. Some pages especially those magazine clippings that were not adhered to pages may have irrelevant page backs included. Please send any feedback on this document to nathan@rcaf.info.

Scan by Nathan Kachur of <https://RCAF.info>
taken May 2025

Some portions of this document may be copyrighted, those rights may reserved.

Lockheed
~~Electre~~ R12

Lockheed 212
Serial 7642



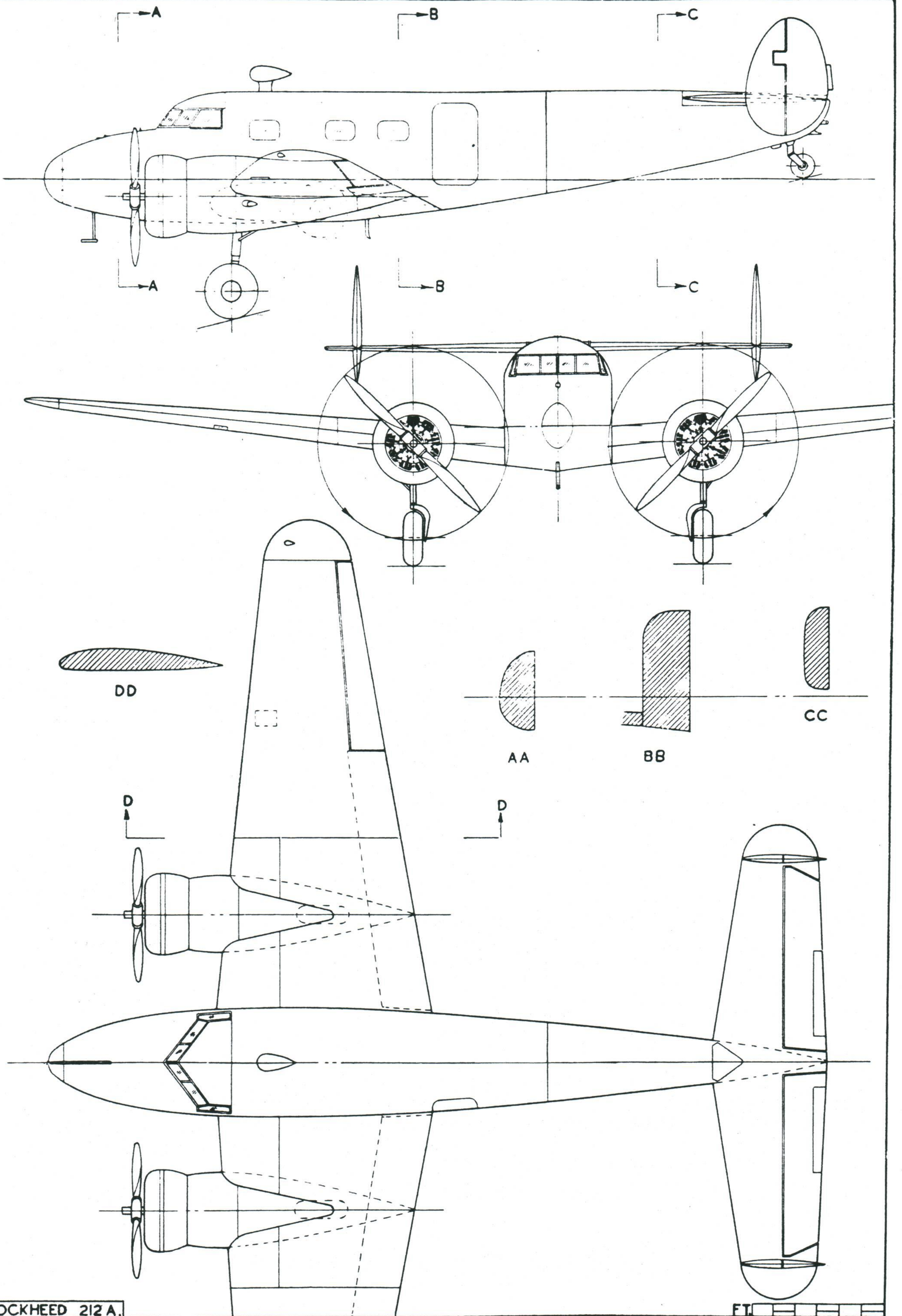

LOCKHEED 212A.

FT. 0 10 20 30

188-1147	188A	TAA	VH-TLC	1
188-1148	188A	National	N5014K	1
188-1149/1168	188A	Cancelled	- - -	0
188-2001	188C	Co. leased	N6934C	1
188-2002	188C	Qantas	VH-ECA	1
188-2003	188C	KLM	PH-LLB	1
188-2004	188C	Qantas	VH-ECB	1
188-2005	188C	Co. leased	N9724C	1
188-2006	188C	KLM	PH-LLC	1
188-2007/2008	188C	Qantas	VH-ECC/VH-ECD	2
188-2009	188C	KLM	PH-LLD	1
188-2010/2011	188C	TEAL	ZK-TEB/ZK-TEC	2
188-2012/2016	188C	KLM	PH-LLE/PH-LLI	5
188-2017/2019	188C	KLM	PH-LLK/PH-LLM	3
188-2020/2022	188C	Garuda	PK-GLA/PK-GLC	3
LOCKHEED LASA-60 (Number built: 2 by Lockheed; plus 18 by Lockheed-Azcarate SA)				
	LASA-60	Co. owned	N601L & N602L	2
LOCKHEED P-3 ORION (Number built: 522 up to end of 1980; still in production)				
185-1003	YP3V-1	USN	148276	(1)
185-5001/5003	P-3A-1-LO	USN	148883/148885	3
185-5004/5007	P-3A-5-LO	USN	148886/148889	4
185-5008/5013	P-3A-10-LO	USN	149667/149672	6
185-5014/5019	P-3A-15-LO	USN	149673/149678	6
185-5020/5031	P-3A-20-LO	USN	150494/150505	12
185-5032/5046	P-3A-25-LO	USN	150506/150520	15
185-5047/5055	P-3A-30-LO	USN	150521/150529	9
185-5056/5061	P-3A-30-LO	USN	150604/150609	6
185-5062/5073	P-3A-35-LO	USN	151349/151360	12
185-5074/5089	P-3A-40-LO	USN	151361/151376	16
185-5090/5109	P-3A-45-LO	USN	151377/151396	20
185-5110/5125	P-3A-50-LO	USN	152140/152155	16
185-5126/5141	P-3A-55-LO	USN	152156/152171	16
185-5142/5157	P-3A-60-LO	USN	152172/152187	16
185-5158/5173	P-3B-65-LO	USN	152718/152733	16
185-5174/5189	P-3B-70-LO	USN	152734/152749	16
185-5190	P-3B-70-LO	RNZAF	NZ4201	1
185-5191	P-3B-70-LO	USN	152750	1
185-5192	P-3B-70-LO	RNZAF	NZ4202	1
185-5193/5199	P-3B-75-LO	USN	152751/152757	7
185-5200	P-3B-75-LO	RNZAF	NZ4203	1
185-5201	P-3B-75-LO	USN	152758	1
185-5202	P-3B-75-LO	RNZAF	NZ4204	1
185-5203/5207	P-3B-75-LO	USN	152759/152763	5
185-5208	P-3B-75-LO	RNZAF	NZ4205	1
185-5209/5210	P-3B-75-LO	USN	152764/152765	2
185-5211/5225	P-3B-80-LO	USN	153414/153428	15
185-5226/5238	P-3B-85-LO	USN	153429/153441	13
185-5239	P-3B-90-LO	USN	153442	1
185-5240/5254	P-3B-90-LO	USN	153444/153458	15
185-5255/5261	P-3B-95-LO	USN	154574/154580	7
185-5262/5272	P-3B-100-LO	USN	154581/154591	11
185-5273/5285	P-3B-105-LO	USN	154592/154604	13
185-5286	P-3B-105-LO	USN (RAAF)	154605 (A9-605)	1
185C-5301/5305	P-3B- -LO	Norwegian AF	KK-L/KK-P	5
185B-5401/5405	P-3B- -LO	RAAF	A9-291/A9-295	5
185B-5406	P-3B- -LO	RAAF (destroyed)	A9-296	1
185B-5407/5410	P-3B- -LO	RAAF	A9-297/A9-300	4
285A-5500	YP-3C-LO	USN	153443	1
285A-5501/5515	P-3C-110-LO	USN	156507/156521	15
285A-5516/5524	P-3C-115-LO	USN	156522/156530	9
285A-5525/5535	P-3C-120-LO	USN	157310/157320	11
285A-5536/5547	P-3C-125-LO	USN	157321/157332	12
285A-5548/5550	P-3C-130-LO	USN	158204/158206	3
285A-5551	RP-3D- -LO	USN	158227	1
285A-5552/5559	P-3C-130-LO	USN	158207/158214	8
285A-5560/5571	P-3C-135-LO	USN	158215/158226	12
285A-5572/5583	P-3C-140-LO	USN	158563/158574	12
285A-5584/5601	P-3C-145-LO	USN	158912/158929	18
285A-5602/5607	P-3C-150-LO	USN	158930/158935	6
285A-5608/5617	P-3C-155-LO	USN	159318/159327	10
285A-5618/5619	P-3C-160-LO	USN	159328/159329	2
285A-5620/5621	P-3C-165-LO	USN	159503/159504	2

285A-5622	WP-3D- -LO	NOAA	159773 (N42RF)	1
285A-5623/5632	P-3C-165-LO	USN	159505/159514	10
285A-5633	WP-3D- -LO	NOAA	159875 (N43RF)	1
285A-5634/5645	P-3C-170-LO	USN	159883/159894	12
285A-5646/5652	P-3C-175-LO	USN	160283/160289	7
285A-5653/5657	P-3C-180-LO	USN	160290/160294	5
285D-	P-3C- -LO	RAAF	A9-751/A9-760	10
285B-	CP-140	Can. Forces	140101/140118	18
785A-7001/7003	P-3C- -LO	JMSDF	4801/4803	3
785A-7004/7007	P-3C- -LO	JMSDF	4804/4807	4
785A-7008/7045	P-3C- -LO	JMSDF	4808/4845	38
285E-	P-3C- -LO	MLD		13
685A-6001/6006	P-3F- -LO	IIAF	5-256/5-261	6
LOCKHEED CL-475 (Number built: 1)				
	CL-475	Co. owned	N6940C	1
LOCKHEED YF-12 and SR-71 (Number built: at least 57 according to released information)				
	A-11	USAF	60-6924/60-6933	10
	YF-12A-LO	USAF	60-6934/60-6936	3
	YF-12C-LO	USAF	60-6937	1
	A-11	USAF	60-6938/60-6948	11
	SR-71A-LO	USAF	64-17950	1
	SR-71B-LO	USAF	64-17951	1
	SR-71A-LO	USAF	64-17952/64-17955	4
	SR-71B-LO	USAF	64-17956	1
	SR-71A-LO	USAF	64-17957/64-17980	24
	SR-71C-LO	USAF	64-17981	1
	SR-71A-LO	Cancelled?	64-17982/64-17984	0
LOCKHEED HUMMINGBIRD (Number built: 2)				
	VZ-10-LO	USA	62-4503/62-4504	2
LOCKHEED 186 and 286 (Number built: 5)				
186-1001/1002	XH-51A-LO	USA/USN	151262/151263	2
186-1003	XH-51N-LO	NASA	NASA 531	1
286-1004/1005	286	Co. owned	N286L & ?	2
LOCKHEED C-141 STARLIFTER (Number built: 285)				
300-6001/6002	C-141A-1-LM	USAF	61-2775/61-2776	2
300-6003/6005	C-141A-5-LM	USAF	61-2777/61-2779	3
300-6006/6021	C-141A-10-LM	USAF	63-8075/63-8090	16
300-6022/6046	C-141A-15-LM	USAF	64-609/64-633	25
300-6047/6066	C-141A-20-LM	USAF	64-634/64-653	20
300-6067/6109	C-141A- -LM	USAF	65-216/65-258	43
300-6110	L-300-50A	Demonstrator	N4141A	1
300-6111/6133	C-141A- -LM	USAF	65-259/65-281	23
300-6134/6151	C-141A- -LM	USAF	65-9397/65-9414	18
300-6152/6235	C-141A- -LM	USAF	66-126/66-209	84
300-6236/6251	C-141A- -LM	USAF	66-7944/66-7959	16
300-6252/6282	C-141A- -LM	USAF	67-001/67-031	31
300-6283/6285	C-141A- -LM	USAF	67-164/67-166	3
LOCKHEED Q-STAR and YO-3A (Number built: 17)				
- - -	QT-2	Co. owned	N2471W & N2472W	2
- - -	Q-Star	Co. owned	N5713S	1
001/014	YO-3A-LM	USA	69-18000/69-18013	14
LOCKHEED AH-56 CHEYENNE (Number built: 10)				
187-1001/1010	AH-56A-LO	USA	66-8826/66-8835	10
LOCKHEED C-5 GALAXY (Number built: 81)				
500-0001/0005	C-5A- -LM	USAF	66-8303/66-8307	5
500-0006/0013	C-5A- -LM	USAF	67-167/67-174	8
500-0014/0031	C-5A- -LM	USAF	68-211/68-228	18
500-0032/0058	C-5A- -LM	USAF	69-001/69-027	27
500-0059/0081	C-5A- -LM	USAF	70-445/70-467	23
LOCKHEED L-1011 TRISTAR (Number built: 195 up to end of 1980; still in production)				
193A-1001	L-1011-1	Co. owned	N1011	1
193A-1002	L-1011-1	Eastern	N301EA (N1031L)	1
193A-1003	L-1011-1	Eastern	N302EA (N301EA)	1
193A-1004	L-1011-1	Eastern	N303EA	1
193A-1005	L-1011-1	Eastern	N304EA (N6752)	1

Type	Registration	c/n	Previous	Transfer Registration	Registration after RCAF	Engine	Date on RCAF charge	Date off RCAF charge	Remarks
Lockheed 10A	1526	1112	CF-TCA	CF-BTD	NC-1285	Wasp SB	23.10.39	16.1.46	at F.I.S. Camp Borden
10A	1527	1113	-TCB			"	23.10.39	17.8.44	W/o To spares + produce.
10A	1528	1064	-BAF		CF-HED	"	23.10.39	2.5.46	at F.I.S. Trenton
10A	1529	1063	-AZY		NC 97227	"	23.10.39	2.5.46	To Thunder Bay Airlines
10A/B	7631	1013	NC 14261	CF-BRD	CF-BYU	"	27.6.40	2.3.45	Converted to 10B 21-7-43
A	7632	1010	NC 14263	CF-BRC		"	27.6.40	5.4.46	Sold to Robert Kashower, N.Y.
A	7633	1003	NC 14244	CF-BRB		"	27.6.40	27.2.45	Cat B Crash 14.12.44
B	7634	1040	NC 14962	CF-BQW	CF-BXQ	Wright R975E-3	27.6.40	25.10.44	Sold to Maritime Central.
B	7648	1066	NC 16054	CF-BRS		"	7-7.40	7.6.45	Total hrs 2784 ¹⁵ Sold w.A.C
B	7649	1059	NC 16024	CF-BRL	CF-BYV	"	7-7.40	2.3.45	Total hrs 9413 ⁴⁹ Sold w.A.C
A	7650	1027	NC 14938	CF-BRE		Wasp SB	2-8.40	2.5.46	Total hrs 11251 ⁰⁰ Sold w.A.C
A	7651	1031	NC 14942	CF-BRF		"	2-8.40	2.5.46	Total hrs 10715 ⁵⁵ Sold w.A.C
A	7652	1001	NC 233Y	CF-BRG		"	2-8.40	13.11.41	Cat A 14.10.41 Mountain View
A	7656	1091	NC 17380	CF-BTB		"	11-9.40	2-5.46	Total hrs 7881 ⁵⁵ Sold w.A.C
A	7841	1012	NC 3128	CF-BSZ		"	21-10.40	6-4.42	Cat A Crash 26-1.42 MacGregor Man.
Lockheed 12	1531	1240	NC 18946			Wasp SB	15.7.41	18.11.44	To Maritime Central Airways
12	7640	1245	NC 18957	CF-BQZ		"	29.6.40	12.3.45	Total hrs 1764 ⁰⁰ Sold w.A.C
12	7641	1241	NC 18947	CF-BRA	CF-BZIN	"	22.6.40	9.5.45	Total hrs 1828 ¹⁵ Sold w.A.C
12	7645	1207	NC 58Y	CF-BRN		"	10.8.40	5-10.44	Sold to Charles Babb + Co
12	7646	1209	NC 17309	CF-BRW	CF-DTP	"	10-8.40	1-12.44	To Dept of Transport (1599 ³⁵ hrs)
12A	7647	1223	NC 18126	CF-BIP		"	10-8.40	1-11.44	Sold to Washower of Ecuador
12A	7653	1216	NC 17342	CF-BRK		"	21.8.40	14.11.44	Sold to C.H. Babb Co Ltd.
12A	7654	1210	NC 17310	CF-BRT	CF-DTQ	"	21.8.40	1-12.44	To Dept of Transport (2645 ²⁰ hrs)
12A	7837	1222	NC 18125	CF-BRQ	CF-BZM	"	1-10.40	12.3.45	Total hrs 1993 ¹⁵ Sold w.A.C
12	7838	1206	NC 13318	CF-BRV		"	3-10.40	9.5.45	Total hrs 5890 Sold w.A.C
Lockheed 212	7642	212-13	NX 18955	CF-BQX		Wasp SB	29.6.40	1-2.46	Sold to Algoma Air Transport

NB WAC = War Assets Corp.

REMARKS:

RECORD OF WRITE-OFF

APPLICATION RC'D FROM	DATE	FILE No.	DATE APPROVED	APPROVED BY	APPROVAL SENT TO	DATE	T. O. No.

DISPOSAL PARTICULARS

AIRFRAME	T. O. No.
ENGINE/S (QUOTE SERIAL NOS.)	T. O. No.
AIRSCREW/S (QUOTE SERIAL NOS.)	
ACCESSORIES	
REMARKS:	EFFECTIVE DATE WRITTEN-OFF

AIRCRAFT RECORD CARD

FIRST ENTRY AT *No. 1 Training Command* DATE *29/6/40* TRANSFER ORDER NO. *830*

TRANSFERS			TRANSFERS		
DATE	TO	AUTHORITY	DATE	TO	AUTHORITY
19/11/42	Head Base 701 T.C.	T.O. 2923			
<i>5.1.43</i>	<i>Stored Reserve 1TC</i>	<i>T.O. 4827</i>			
<i>15.2</i>	<i>"3 T.C. H.W.E.</i>	<i>T.O. 5583</i>			
<i>15.11.44</i>	<i>C.A.C. (1 J.S.W.)</i>	<i>T.O. 17106</i>			
<i>21.9.45</i>	<i>Stored Reserve #1AC</i>	<i>T.O. 14543</i>			
<i>21.46</i>	<i>Apdal MC: (Admin Unit Wplank)</i>	<i>To MC 15993</i>			
<i>1/2/46</i>	<i>Wav Assets, Algonia</i>	<i>To MC 16278</i>			
	<i>Air Transport</i>				
	<i>South Porcupine</i>				

REMARKS *15/2/43:- TO BE USED BY SQN. LDR. MCARTHUR ON SPECIAL WORK. ON CHARGE OF #12 COMM. SQN. (ON LOAN TO H.W.E.)*

USED AIRCRAFT
 FORMERLY U.S. REGISTRATION NX 18955 *27.9.44. Line. Since new. 2519:55. Since overhaul. 772:00*
 VALUE: \$50,250
Line since new 2227:50
o/h 849:15 *Car Equip*

ENGINE TYPE WASP JR. SB	UNITS 2	AIRSCREW TYPE (CODE)	REF. No.
BATCH No.	QUAN. IN BATCH TP 814	LEDGER FOLIO 1200-38-12	SPECIFICATION No.
REGISTRATION No. 7642	MAKE & MODEL LOCKHEED 212	YEAR 1940	TYPE T E TRAINER
			MANUFACTURERS No. (CF-BOX) 212-13

7642

CF-BQX

